



COMPARING ENVIRONMENTAL IMPACTS OF NATURAL INERT AND RECYCLED CONSTRUCTION AND DEMOLITION WASTE PROCESSING USING LCA

Isabela Maria Simion^a, Maria Emiliană Fortuna^{a, c}, Alessandra Bonoli^b, Maria Gavrilăscu^{a, d}

^a*Department of Environmental Engineering and Management, Faculty of Chemical Engineering and Environmental Protection, “Gheorghe Asachi” Technical University of Iasi, 73 Prof Dr Docent Dimitrie Mangeron Street, 700050 Iasi, Romania*

^b*DICAM, Alma Mater Studiorum University of Studies of Bologna, 2 Risorgimento Street, 40136 Bologna, Italy*

^c*Petru Poni Institute of Macromolecular Chemistry, 41A Grigore Ghica Voda Alley, 700487 Iasi, Romania*

^d*Academy of Romanian Scientists, 54 Splaiul Independentei, 050094 Bucharest, Romania*

Submitted 28 March 2012; accepted 03 Oct. 2013

Abstract. Construction and demolition wastes (C&DW) are usually recognized as not dangerous, but their accumulation can generate serious environmental problems. In spite of C&DW high potential to be reused/recycled, the practical procedures need to be assessed in terms of environmental consequences. The objective of this study is to quantify the environmental impacts of C&DW recycling/reuse, specifically in the production of aggregate 0/30 mm, comparative to those generated during the natural inert processing, in terms of global impacts addressing the whole process and for each technological phase. The analysis was carried out using Life Cycle Assessment methodology, assisted by SimaPro software, and based on primary data collected directly from the Italian Emilia Romagna region. Three methods were used for impact quantification: *Eco-Indicator 99*, *EDIP/UMIP* and *Cumulative Energy Demand*. The analysis revealed that the environmental impacts generated by C&DW recycling/reuse accounting for about 40% of the impacts induced by natural inert processing.

Keywords: C&DW, energy, environmental impact, Life Cycle Assessment, natural inert, recycling.

Reference to this paper should be made as follows: Simion, I. M.; Fortuna, M. E.; Bonoli, A.; Gavrilăscu, M. 2013. Comparing environmental impacts of natural inert and recycled construction and demolition waste processing using LCA, *Journal of Environmental Engineering and Landscape Management* 21(4): 273–287. <http://dx.doi.org/10.3846/16486897.2013.852558>

Introduction

Waste generation is the result of inefficient and unsustainable uses of natural resources and energy in production processes, which leads to economic and environmental problems, such as large additional expenses for the collection, processing and waste landfilling and elimination (Dall’Ara *et al.* 2012; Schiopu *et al.* 2012; Simion *et al.* 2012; Taboada-González *et al.* 2012; Yeheyis *et al.* 2012). The enormous production of waste generated during various anthropogenic activities induces the need to extend the life cycle of the products as well as the producer responsibilities, which is a subject of great interest for

scientific research, as well as for various actors involved in production processes and waste treatment and management (del Rio Merino *et al.* 2010; Vlase *et al.* 2012; Wiesmeth, Hackl 2011). One of the key issues of a continuous progress is ensuring the sustainable management of prevention, control and remediation processes relative to the environmental components, associated in particular to waste minimization and valorization (Gavrilăscu 2004; Simion *et al.* 2013).

In this context, a sustainable approach should address various procedures for reducing waste and/or for the optimization of waste recovery, recycle and reuse as well as its processing in various ways (Agamuthu 2008; del Rio

Merino *et al.* 2010; Fortuna *et al.* 2012; Ghinea, Gavriles-cu 2010; Petraru, Gavriles-cu 2010; Rigamonti *et al.* 2009; Schiopu, Gavriles-cu 2010).

Construction and demolition wastes (C&DW) include diverse categories of materials that, when recovered, can represent high-value materials and resources for new construction (EPA 2002; Simion *et al.* 2013). However, C&DW is a significant part of the total solid waste streams, since building materials account for almost half of all materials used and about half the solid waste generated worldwide (Cochran *et al.* 2007; Dosal *et al.* 2012; Edge Environment 2011; Kourmpanis *et al.* 2008; Vasquez 2013). An Australian report shows that C&DW generation in Australia during 2004–2005 “was 15.1 million tonnes, of which 7.6 million tonnes was recycled materials (timber, steel, concrete, rubble and soil) and 7.5 million tonnes was residual waste to landfill. In 2006–2007, 43,777,000 tonnes of waste was generated, 38 per cent of which was from C&DW” (Edge Environment 2011). C&DW represents 10–30% of total waste generation in Europe, which means about 180 million tonnes per year, approximated at 480 kg per person. While only 28% is recycled, the rest

of 72% is disposed (Bressi, Puia 2000; EPA 2002; Pittalis 2009; Poon 2007). Table 1 shows the amounts of C&DW generated yearly in European countries in 2006–2010 (Eurostat 2013). On the other hand, large quantities of natural primary aggregates and building materials are extracted each year due to increasing demands. At a global level, 60% of the raw materials extracted from the lithosphere are used for civil works and building construction. In Europe, the extraction of minerals for building is about 4.8 tonnes per inhabitant per year, which is 64 times the average footprint per person (Bribián *et al.* 2011; Simion *et al.* 2013).

Unfortunately, materials resulting from construction and demolition are often considered as **waste** for disposal, rather than **resources** for processing and reuse. They have negative impacts on environment, economy, public health and social life (Ionescu *et al.* 2011; Robu *et al.* 2007; SARMa 2011; Yeheyis *et al.* 2012). Governmental regulation and legislation worldwide can be considered as positive reactions to the need of waste minimization, since they often generated the market framework for building materials and products resulting from the construction and

Table 1. C&DW generation in the European countries during 2004–2010 (Eurostat 2013)

Country	Time			
	2004	2006	2008	2010
France	3.461	3.680	3.942	4.011
Austria	3.418	3.788	3.765	1.074
Netherlands	3.047	3.464	3.617	4.698
Ireland	2.773	3.896	0	360
Germany (until 1990 former territory of the FRG)	2.322	2.386	2.402	2.336
United Kingdom	1.658	1.808	1.645	1.695
European Union (27 countries)	1.576	1.708	1.721	1.713
Sweden	1.142	985	359	1.000
Spain	1.085	1.073	986	824
Belgium	1.059	1.241	1.1442	1.667
Italy	845	888	1.165	981
Czech Republic	796	816	1.022	889
Denmark	791	1.067	1.033	572
Cyprus	660	386	544	1.288
Slovenia	455	496	681	737
Bulgaria	385	133	240	10
Estonia	362	534	820	326
Greece	300	613	608	184
Slovakia	261	170	241	329
Portugal	250	341	761	1.041
Norway	240	269	314	316
Hungary	172	302	323	307
Croatia	145	–	29	2
Lithuania	104	103	123	109
Iceland	63	–	–	–
Poland	52	371	182	545
Latvia	4	8	5	10
Romania	4	2	15	11
European Union (15 countries)	–	–	–	–
Turkey	–	–	0	0

demolition (C&DW) waste streams (Edge Environment 2011).

However, it is very difficult to know correct data and establish statistics with any degree of confidence because this form of waste is deposited both legally and illegally. Also C&DW is often not recorded as a separate waste stream, or is recorded incorrectly. Besides, there seems to be confusion regarding the status of clean fill materials that can be accepted for landfills establishment according to European regulations (Bonoli, Garfi 2008; Dosal *et al.* 2012).

Even though this material is derived from construction or building projects, it is seldom recorded as C&DW (EPA 2002; Simion *et al.* 2013).

The demolition of walls or renovation in course of restructuring activities are perhaps the most immediately reminded of to the memory of the ordinary citizen, in connection with the mounds of rubble often improperly abandoned on roads and bank river (Balázs *et al.* 2010; D'Andrea 1999).

1. Structure of C&DW and recycling/reuse framework

Most of the materials obtained during dismantling can be recycled and, if they receive an appropriate treatment process, can become recycled raw materials that find their target market materials for building and for construction in civil engineering works. These products can be used for many applications often quite comparable to performance those of natural aggregates (Bonoli *et al.* 2006; Taranu *et al.* 2012). In order to increase the recycling amounts of C&DW it is necessary to know the specific composition of this waste (Dosal *et al.* 2012; Simion *et al.* 2013). The typical components of C&DW include concrete, asphalt, wood, metal, drywall, and smaller amounts of packaging materials, such as paper and plastic (Coronado *et al.* 2011). However, C&DW has a very inconsistent composition according to local building techniques, climate, economic activities, technological development in the area, available raw materials (Table 2). Their characteristics depend in a high degree on the region and involve large numbers of stakeholders (Coelho, de Brito 2013; Taranu *et al.* 2012).

The enormous quantities of C&DW produced by many anthropogenic activities generate the need of its recycling: this is to reduce withdrawals from quarries of natural materials and at the same time to reduce the quantities of waste disposed in landfills. That's in accordance with European directives and national laws envisage the achievement of important objectives of recycling and recovery. Directive 2008/98/EC on waste incorporates the need to quantify the waste stream and to improve the C&DW recovery efficiency in the European Union

(EC Directive 2008). Moreover, the European Commission considers C&DW as a priority in waste stream management due to large quantities produced yearly and, above all, following its high potential for reuse and recycling embedded in the waste structure (Coronado *et al.* 2011; Solís-Guzmán *et al.* 2009).

Table 2. Compositions of C&DW in Europe (EPA, 2002)

Material	Percentage of total fill (%)
Concrete	20–50
Bricks	5–20
Timber	5–20
Steel	5–15
Soil	15–70
Green Waste	5–20
Plastic	5

Certainly, recycling and waste reprocessing are highly affected by this situation and their own impacts, mostly due to transporting and reprocessing the materials recovered could be increased by any inconsistency in waste composition. All these can weaken the benefits from recycling, so as it is necessary to examine the lifecycle as a whole and quantify the environmental impacts, based on an adequate knowledge of the inputs to material recovery facilities, even more the Landfill Directive asks the recycling target of C&DW by 2020 to be 70% (Bribian *et al.* 2011; Coronado *et al.* 2011). The optimization of recycling operations in dedicated facilities is necessary in order to achieve this target, so as it is necessary to group the waste into homogeneous fractions by (Bonoli *et al.* 2006):

- selection of raw materials and their appropriate storage containers;
- separation of waste to facilitate the treatment.

The recycling of building materials has its origin in the time of the total or partial demolition of a manufactured housing (Mymrin, Correa 2007; Rigamonti *et al.* 1996). Demolition technique adopted is closely related with waste valorization: in fact, it has a direct influence on the quality of waste produced and of recycled materials. Those recycled materials deriving from treated homogeneous waste possess a higher quality than those coming from a heterogeneous mix (Pitalis 2009; Taranu *et al.* 2012).

These actions are feasible if the building processes use less natural resources and energy, and do not generate more waste than the production processes of similar products using virgin resources. Furthermore, at present the cost implications of preparing recycled or reused materials are often unclear (Gorgolewski *et al.* 2006; Bressi 1999).

In particular, the use of C&DW after adequate treatment for civil engineering purposes may bring economic

and environmental advantages due to the lesser need for their transportation to landfill, reduced spaces designed for authorized dumps, and to the considerable savings in traditional quarry materials (Cupo-Pagano *et al.* 1994). The Life Cycle Assessment (LCA) tool makes possible a specific examination of particular construction waste streams, taking into account impacts occurring over the entire life cycle. There are numerous studies published in which the LCA is applied to evaluate the impact of different construction materials and solutions (Bribián *et al.* 2011; Khasreen *et al.* 2009; Koroneos, Dompros 2007).

The aim of this paper is to analyze the processes and materials involved in the Italian C&DW management system and the environmental benefits of C&DW recycling/reuse. Based on the above consideration, in this study we developed a life cycle assessment approach to compare the recycling/reuse scenario of C&DW management with the conventional scenario, which processes natural inert, against a range of environmental criteria. Two scenarios were considered:

- *scenario 1*: production of *aggregate 0/30 mm* from natural inert quarries (Fig. 1);
- *scenario 2*: production of *aggregate 0/30 mm* from C&D inert waste (Fig. 2).

The two scenarios specific for the Italian Emilia Romagna region are discussed and evaluated based on their environmental impact, exploiting the facilities offered by simulation software SimaPro 7.3.3, offered by the DICAM University of Bologna.

2. Materials and method

2.1. LCA methodology

Customarily related to the analysis of products and materials, the use of LCA has extended in recent years to cover larger processes and services such as waste management (Curan 1996; Powell *et al.* 1996). In this study the methodological standards ISO 14040:2006 and ISO 14044:2006 were used. According to these standards, Life Cycle Assessment (LCA) is an internationally standardized methodology for environmental assessment, applied to evaluate the environmental impact of a product or system (ISO 2006a, b; Comandaru *et al.* 2012; Georgakellos 2011; Ghinea *et al.* 2012). LCA consists of four steps: goal and scope definition, inventory analysis, impact assessment and interpretation (Curan 1996; Ghinea, Gavrilescu 2010b; Ghinea *et al.* 2012; Iosip *et al.* 2010; ISO 2006a, b). This methodology can be used for modeling and simulation of waste management scenarios, supported by SimaPro software, while all of the data needed for the life cycle inventory are collected from the literature, the database of the software and the municipal waste services (Kazemi *et al.* 2012). With SimaPro software tool, life cycle balances were elaborated and analyzed in specific ways.

2.2. Goal and scope definition

The aim of the present analysis was to provide multiple criteria for decision-making, according to the values of three different methods to assess impact categories for the two scenarios: **natural inert processing** (*scenario 1*) and **C&DW recycling/reuse** (*scenario 2*). The three methods applied for impact assessment are: *Eco-Indicator 99*, *EDIP/UMIP* and *Cumulative Energy Demand*.

The focal point is the inert waste, and the data are compared to those for natural inert materials, related to 1 tonne of processed material as the functional unit. The boundaries of the systems are drawn so as to comprise all significant impacts.

2.3. Production and reuse of C&DW – system boundaries

In the first step of LCA the boundaries of systems are defined to identify inputs and outputs, so as to consider all processes, the input data on energy flows and material flows and output data related to specific issues. The necessary treatment for C&DW recycling/reuse as raw materials in new processes consists in: preliminary separation, primary crushing, direct classification or screening, secondary crushing and new separation. An efficient plant is equipped with a technological line, which allows the separation the incoming material into three streams: a stone material, a light fraction (paper, plastic, wood), a metal fraction (Bonoli *et al.* 2006).

2.4. Inventory analyses phase

The inventory phase is conducted by collecting all information, using specific methods that were analyzed comparatively with studies from literature and software libraries, for all the sectors involving materials, energy and fuels. Natural inert and inert wastes are analyzed in all their phase of processing, normalized to the functional unit (1 tonne) of material entering in the systems. The database BUWAL 250 was used for all stages of assessment, excepting the distribution of waste and iron extraction, for which the Ecoinvent database has been used.

After data inventory collection and data normalization to the functional unit, the environmental impact was evaluated.

2.5. Life cycle impact assessment

Life cycle impact assessment is the phase in the LCA aiming at understanding and evaluating the magnitude and significance of the potential environmental impacts of a product system. The life cycle of a product ranges from resource extraction via material processing, manufacturing, and product use or service delivery, to recycling, and to the disposal of any remaining waste.

For the production system aggregate 0/30 mm from quarry material, the LCA is conducted based on the *cradle-to-gate* approach. In fact, the study begins with the procurement of raw materials and ends with placing the product on the market. For the production aggregate 0/30 mm system by processing C&DW, the LCA is conducted with *gate-to-gate* approach, which means that the study examines only the treatment of the waste in the recycling plant. The inputs and outputs taken into consideration are reported, both in the case of production of the natural inert or the recycling of inert waste. The impact categories to analyze in this study were selected considering the current energy and environmental problem in the European area (Bribián *et al.* 2011).

3. Results and discussions

3.1. Impact assessment for processing scenarios

Impacts evaluation for the two scenarios (**natural inert processing – scenario 1**, and **C&DW recycling/reuse – scenario 2**), achieved with SimaPro software according to Life Cycle Assessment methodology and based on the three methods (*Eco-Indicator 99*, *EDIP/UMIP* and *Cumulative Energy Demand*) led to interesting results as decision making support, presented below.

3.1.1. Eco-Indicator 99 method

The *Eco-Indicator 99* method is used for the characterization of the impact on *human health, ecosystem quality and resources*. These three categories of impact are denoted as “macro categories”, but these impact categories include

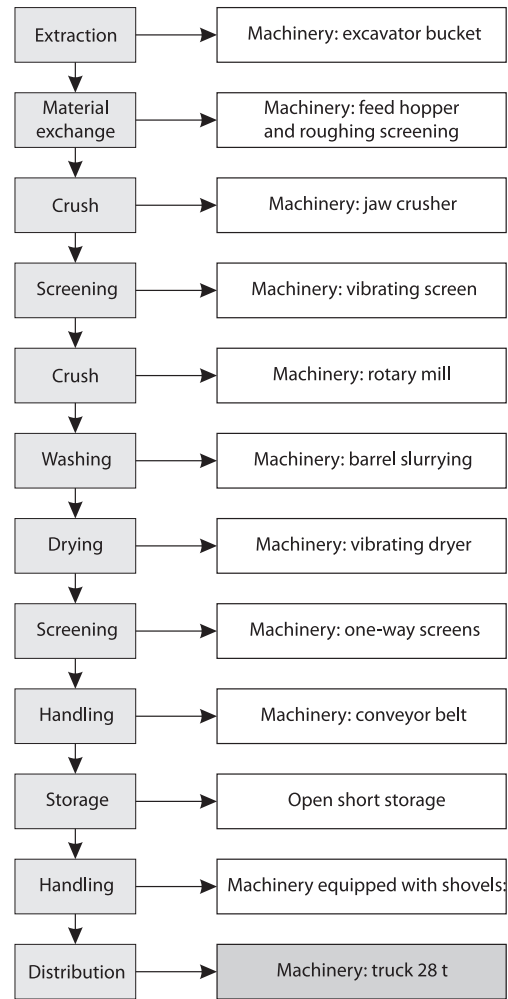

Fig. 1. Scheme of the production process of aggregate 0/30 mm from natural inert material

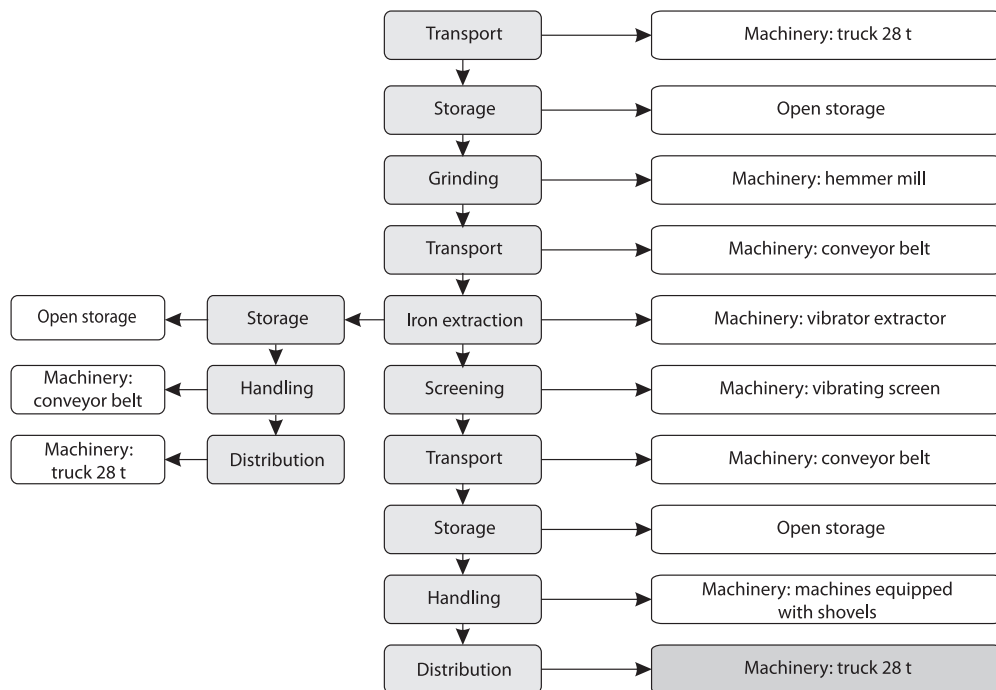

Fig. 2. Scheme of the production process of aggregate 0/30 mm from inert waste

some individual categories of impacts (Table 3). The characterization of the three main categories of impact and of the individual categories is illustrated in Figs 3 and 4, which allow making comparisons between the environmental effects due to the production of *aggregate* in the two analyzed scenarios. It can be seen that the impacts generated by the production of *aggregate* from crushed natural inert are important in terms of human health, ecosystem quality and resources.

Table 3. Impact categories determined with *Eco-Indicator 99* method (Goedkoop et al. 2010)

Human health	Carcinogens
	Respiratory effects (organics)
	Respiratory effects (inorganics)
	Climate changes
	Radiation
	Ozone layer
Ecosystem quality	Ecotoxicity
	Acidification/ Eutrophication
	Land use
Resources	Minerals
	Fossil fuels

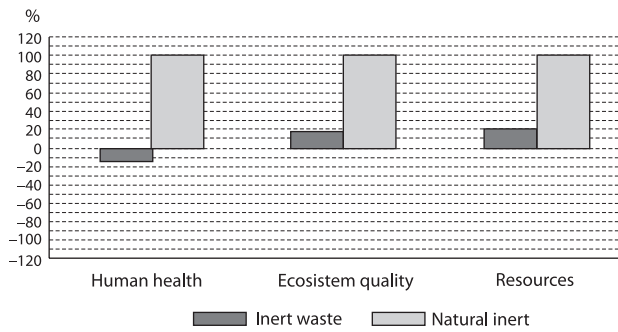

Fig. 3. Characterization of impact with *Eco-Indicator* method

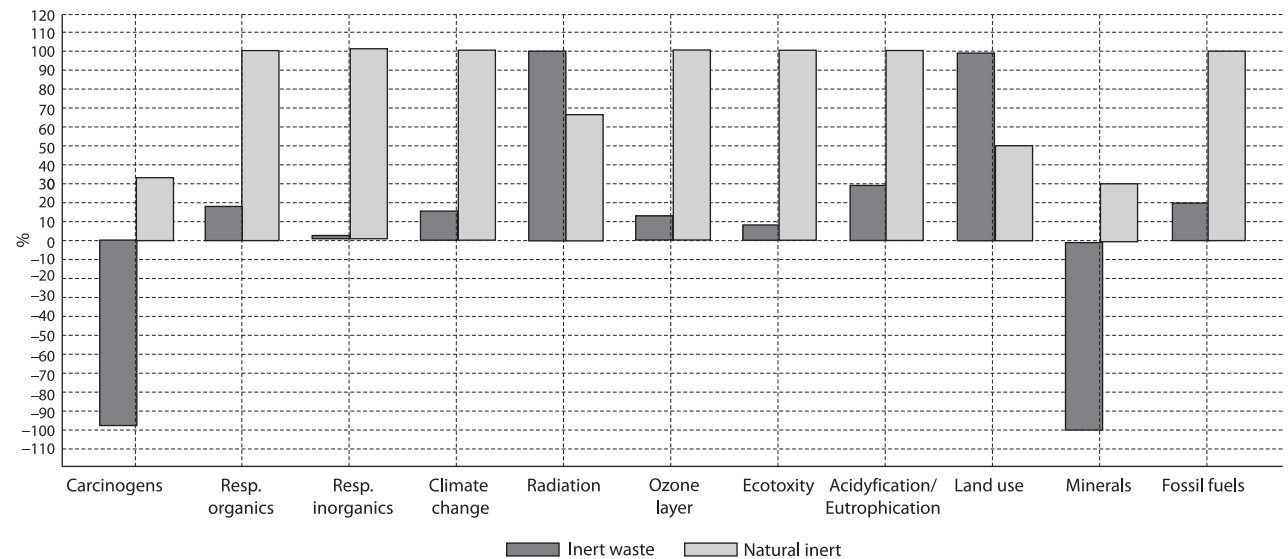

Fig. 4. Characterization of impact categories with *Eco-Indicator* method

On the other hand, C&DW recycling generates positive impacts on human health, and negative impacts on ecosystem quality and resources but accounting for about 20% of the impacts generated by natural inert processing.

If the analysis is detailed by taking into account the individual categories of impacts, it is evident that the two scenarios induce negative impacts for all these subcategories excepting *Carcinogens* and *Minerals*. In these two cases, C&DW recycling generate positive impacts.

However, unlike the situation presented in Fig. 3, C&DW recycling induce high negative impacts in terms of ionizing *Radiation* and *Land Use* (since the temporary storage of waste involves occupation of large areas), while for the other impact categories, the effects of C&DW recycling account for maximum 30% of the impact of *scenario 1*.

The recycling of C&DW allows, therefore, obtaining the same product as from the natural inert quarry, but with much lower impact on humans and the environment, favorizing the conservation of mineral resources, since their extraction generates extensively environmental damages.

3.1.2. EDIP/UMIP method

This method allows the evaluation of various indicators, the most important of which is the Global Warming Potential (GWP), due to greenhouse gas emissions. Other impact categories able to be assessed by the *EDIP/UMIP* are as follows: ozone depletion; acidification; eutrophication; photochemical smog; ecotoxicity (water, chronic); ecotoxicity (soil chronic); human toxicity (air); human toxicity (water); human toxicity (soil); bulk waste; radioactive waste; slags/ashes; resources; hazardous waste.

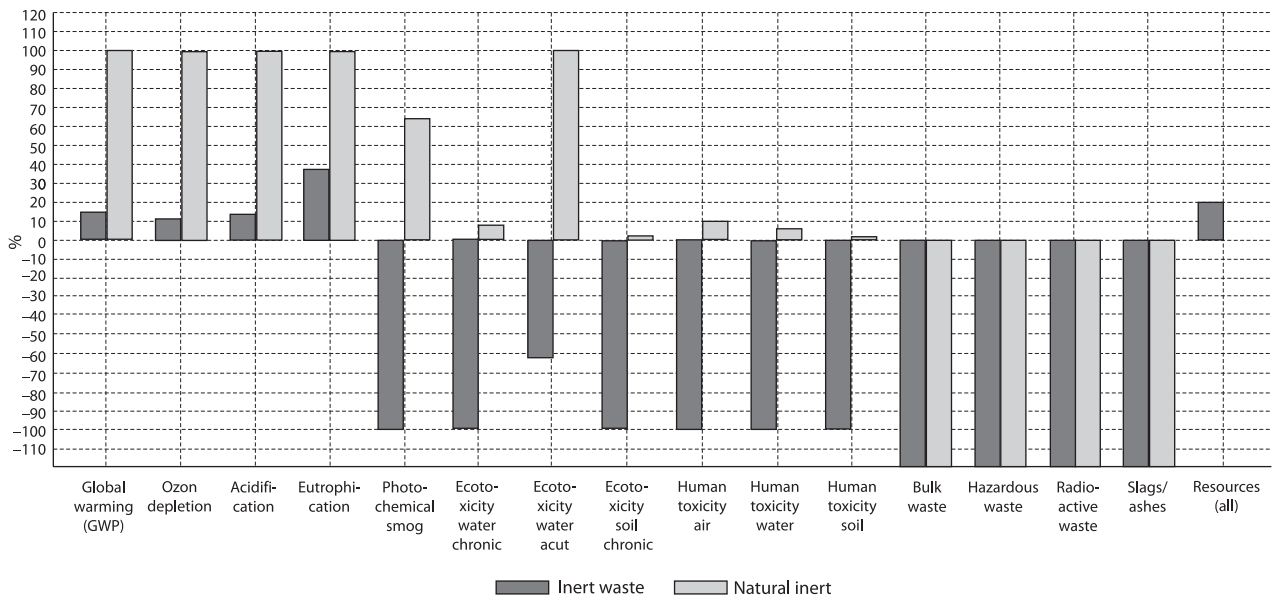

Fig. 5. Characterization of impacts with EDIP/UMIP method

Figure 5 demonstrates that C&DW recycling and reuse (*scenario 2*) generates positive impacts in terms of Photochemical smog, Ecotoxicity of water (chronic, acute), Ecotoxicity of soil, Human toxicity (air, water, soil), bulk waste, hazardous waste, Radioactive waste, Slag/ashes, while the negative impacts account for maximum 40% of those of *scenario 1*.

3.1.3. Cumulative Energy Demand method

This method considers the energy consumption, referring to the different types of energy utilized in all phases of life cycle, as extraction, processing, recycling, etc. measured in MJ (Fig. 6). Overall, the energetic consumption for *scenario 2* is 17% of that for *scenario 1*. Energy consumption for the production of aggregate from C&DW recycling or extracting natural inert material is presented in Figure 6.

It's important to observe that the energy necessary for the production of aggregate from natural inert is higher (1664.11 MJ) than that for inert waste (246.41 MJ). Most of the energy comes from burning fossil fuels, which have a high impact on health and the environment.

The categories of energy taken into account in this analysis are obtained from: fossil fuels, nuclear, biomass, renewable (wind, solar, geothermal, etc.), hydroelectric sources (Table 4). Data from Table 4 shows that there are significant differences between the energy consumption for C&DW recycling/reuse (*scenario 2*) and natural inert processing, as follows:

- the potential consumption of energy from fossil fuel for *scenario 2* is 16% from that associated to *scenario 1*;

- the potential consumption of nuclear energy associated to *scenario 2* is 11% from that for *scenario 1*;
- the energy from biomass is coupled with energy production in *scenario 2*, unlike the situation for *scenario 1*, which consumes energy equivalent to that from biomass;
- the potential consumption of hydroelectric energy for *scenario 2* is 9% from that for *scenario 1*;
- the potential consumption of wind, solar, geothermal energy is similar in the two scenarios.

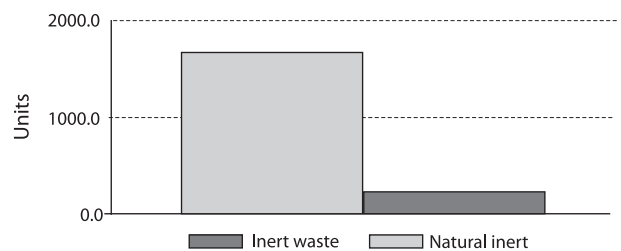

Fig. 6. Energy consumption with Cumulative Energy Demand method

Table 4. Energy consumption for different type of produced energy

	Natural inert (MJ)	Inert waste (MJ)
Fossil fuels	1300	210
Nuclear	185	20.6
Biomass	0.06	-0.09
Wind, solar, geothermal	0.05	0.04
Hydroelectric	178	16.4

3.2. Assessment of impacts associated to various phases for the production of aggregate 0/30 mm by natural inert processing (sce-nario 1)

3.2.1. Eco-Indicator 99 method

The analysis shows that the most impact is generated due to the usage of aggregates for extraction, such as excavator buckets and this is because they have high energy consumption. The resulting impacts are high on human health, quality ecosystems and the consumption of resource (Fig. 7).

Handling and distribution of materials, as other phases of the process have also high environmental impact, even if the order of magnitude is lower than that for extraction, both due to the use of machines such as power shovels and trucks that have substantial fuel consumption and consequently high impact (Fig. 7). However, the primary and secondary crushing have smaller impacts. The same is true in the assessment of impacts for the individual categories expressed in Fig. 8. In this case it is necessary to emphasize that, as regards the categories relating to radiation, the use of the territory and the consumption of minerals play fundamental roles in the distribution phase of the material,

while the other does not contribute to the formation of this kind of impacts.

3.2.2. EDIP/UMIP method

This method takes in account many indicators, including the GWP, as a result of CO₂ emissions.

The Sankey diagram presented in Fig. 9 shows that high GWP due to the production of CO₂ is associated with the extraction of aggregate from the quarry (84,800 g), followed by handling through mechanical shovels (6,890 g) and distribution (4,330 g) respectively. The contribution of the stages of primary and secondary crushing is reduced, respectively 2,030 g of CO₂ and 3,200 g of CO₂, while the steps of screening and washing do not involve the production of carbon dioxide (Fig. 10).

Fig. 10 shows that the extraction of aggregate from the quarry and the distribution of the *aggregate* output from the processing plant induce higher environmental impacts. The first one contributes mostly to the Global Warming Potential, Ozone Depletion, Acidification, Eutrophication, *Photochemical smog*, *Human toxicity* (air) and consumption of *Resources*, while the latter is mainly responsible for *Human toxicity* (water, soil).

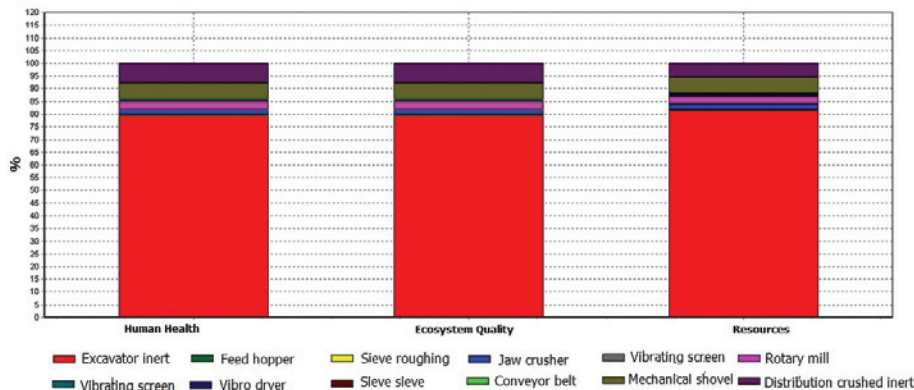

Fig. 7. Characterization of impact category for each phase of *scenario 1* with *Eco-Indicator 99* method

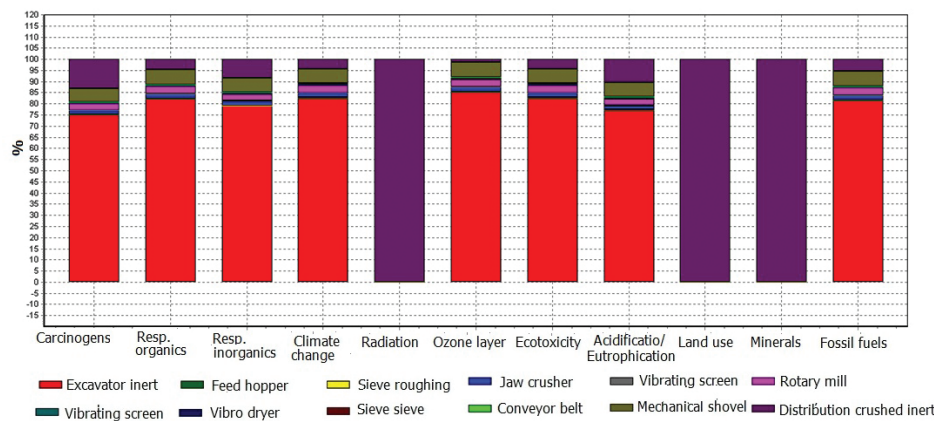

Fig. 8. Characterization of individual impacts for each phase of *scenario 1* with *Eco-Indicator 99* method

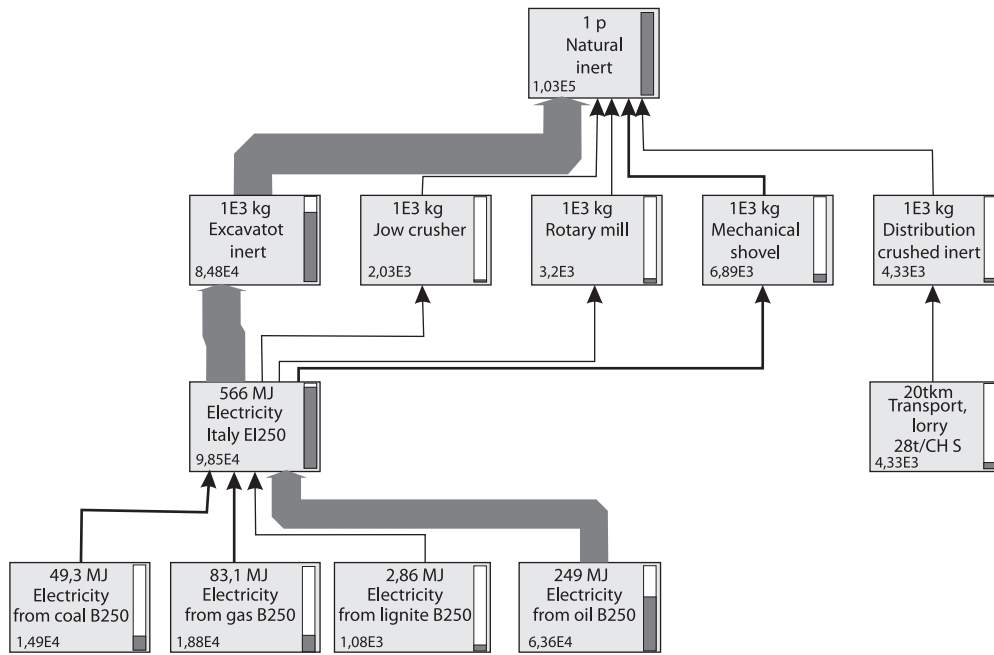

Fig. 9. Mass balance flow sheet (Sankey diagram) for CO₂ produced during natural inert processing, associated to GWP impact category

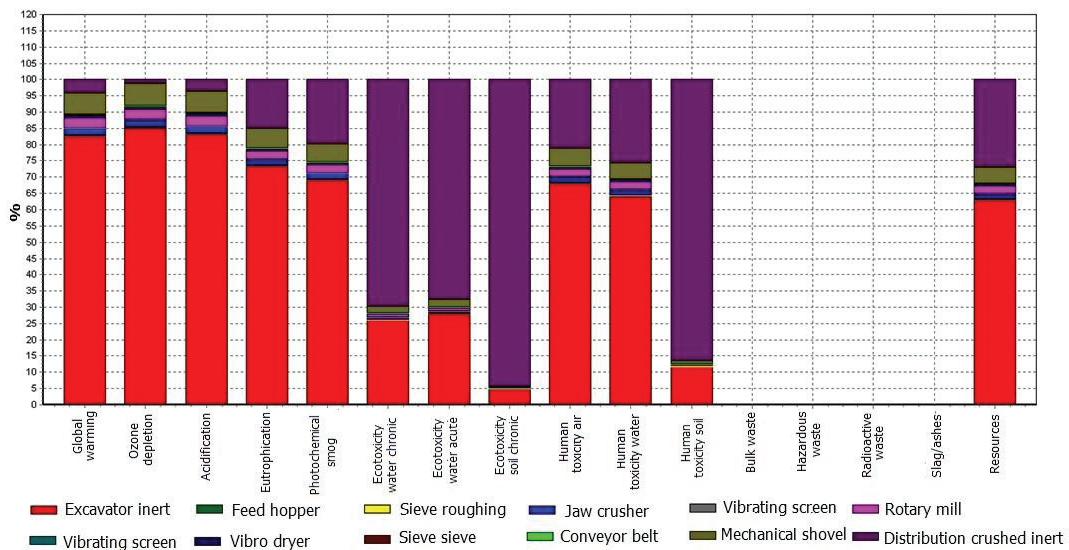

Fig. 10. Characterization of individual impacts for each phase of scenario 1 with EDIP/UMIP method

3.2.3. Cumulative Energy Demand method

From Fig. 11 it can be seen that higher energy consumption (1380 MJ equivalent) is attributable to the extraction stage (the excavation process), followed by material handling by mechanical shovels (111.6 MJ equivalents), transport and distribution by truck (70.95 MJ equivalents), the secondary crusher (51.77 MJ equivalents) and the jaw crusher (33.02 MJ equivalent). In Fig. 11 the steps with lower energy consumption equivalent to 10 MJ were ignored because they contribute to the expenditure of energy to a less significantly degree.

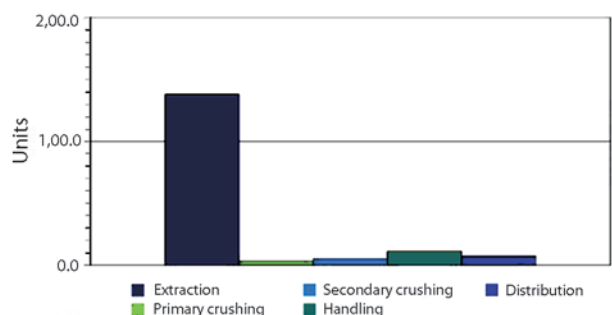

Fig. 11. Energy of individual phases for inert crushed processing

3.3. Assessment of impacts associated to various phases for the production of aggregate 0/30 mm by C&DW recycling/reuse (scenario 2)

3.3.1. Eco-Indicator 99 method

In the production of *aggregate 0/30 mm* by C&DW recycling/reuse, the phases of iron extraction from waste and, respectively the subsequent recycling have environmental and economic positive impacts. In fact, *scenario 2* allows the recovery and sale of various materials that would otherwise be disposed of in landfills (Fig. 12). Table 5 shows the energy consumption related to other phases that take part in the preparation process of *aggregate 0/30 mm* from quarry material. On the other hand, transportation of materials from the scrap yard generates the highest negative impact in terms of *Human health*, followed by materials distribution phase, which is also characterized by high impacts in terms of *Human health* and *Ecosystem quality* (Fig. 13).

Figure 13 also shows that mechanical shovels generate an impact almost equal to that of transport and distribution, if not superior, in the impact categories relating

to the destruction of ozone layer, ecotoxicity and the consumption of fossil fuels.

Table 5. Machinery used in the manufacture of grinding with the consumption less than 10 MJ equivalents

Phases	Energy consumption (MJ equivalent)
Power (hopper)	0.87
Sieving (sieve roughing)	4.39
Screening (vibrating screen)	2.44
Washing (beating slurring)	8.04
Drying (vibro drying)	1.82
Sieving (sieve sieve)	5.76
Handling (conveyor belt)	1.07

Conversely, iron extraction and recycling have positive contributions in almost all impact categories, especially for those related to the carcinogenic effects on respiration due to inorganic substances, ecotoxicity and the consumption of minerals.

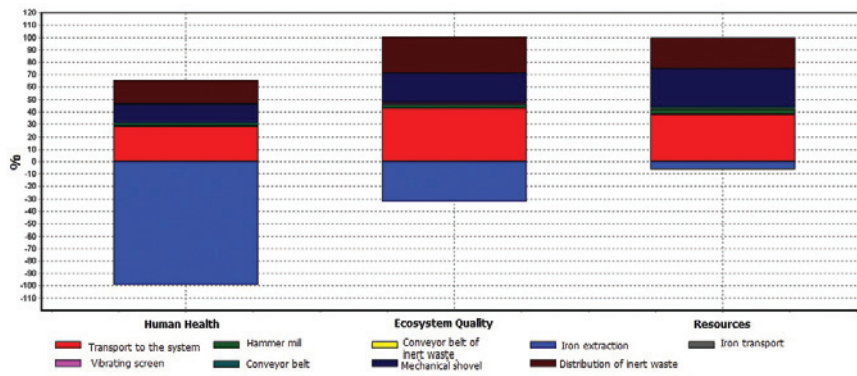

Fig. 12. Characterization of impacts generated by various processing phases involved in C&DW recycling/reuse, based on *Eco-Indicator* method

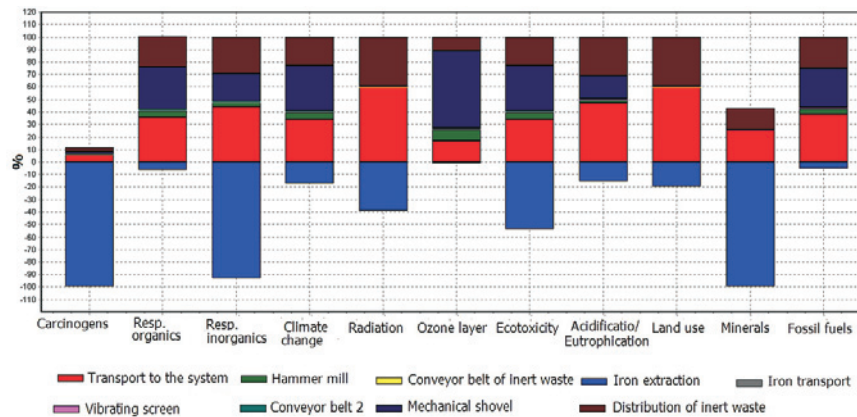

Fig. 13. Characterization of impacts generated in various phases of C&DW recycling/reuse process assessed with the *Eco-Indicator* method

3.3.2. EDIP/UMIP method

The flow diagram of CO₂ balance (Sankey diagram, Fig. 14), closely related to the Global Warming Potential (GWP) highlights that the recycling of iron allows to avoid CO₂ emissions, equivalent to 3430 g. The material handling with mechanical shovels results in emissions of CO₂ equivalent to 6890 g, while the transport system and the distribution of the *aggregate* respectively are associated with CO₂ emissions equivalent to 6,500 g and 4,330 g, respectively (Fig. 14).

Similar arguments apply to sulfur dioxide (SO₂) and nitrogen peroxide (N₂O₄), respectively, responsible for acidification and eutrophication potentials (Fig. 15). SO₂ is generated in particular during handling with mechanical shovels (60.1 g), transport to the waste plant (48 g), distribution of aggregate (32 g) and grinding (8.6 g). The equivalent quantities of N₂O₄ generated during recycling process are of 80.5 g in the transportation of waste, 53.7 g in the distribution of aggregate, 21.1 g in handling with shovels and 3.02 g in grinding. The quantities of these

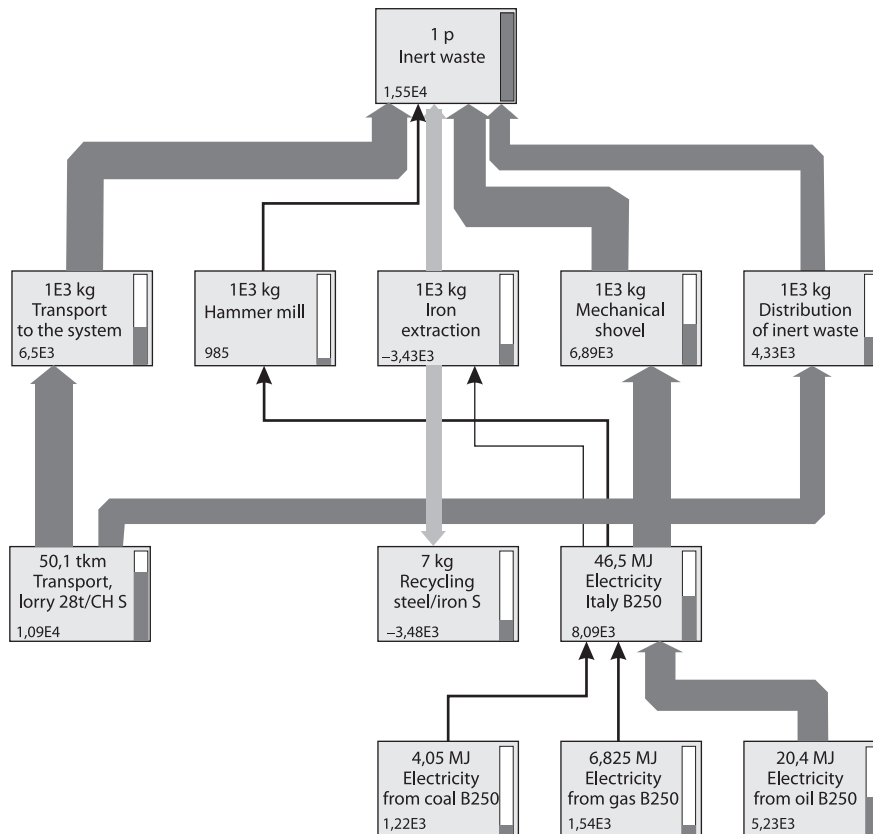

Fig. 14. Mass balance flow sheet (Sankey diagram) for CO₂ produced during C&DW recycling/reuse, associated to GWP impact category

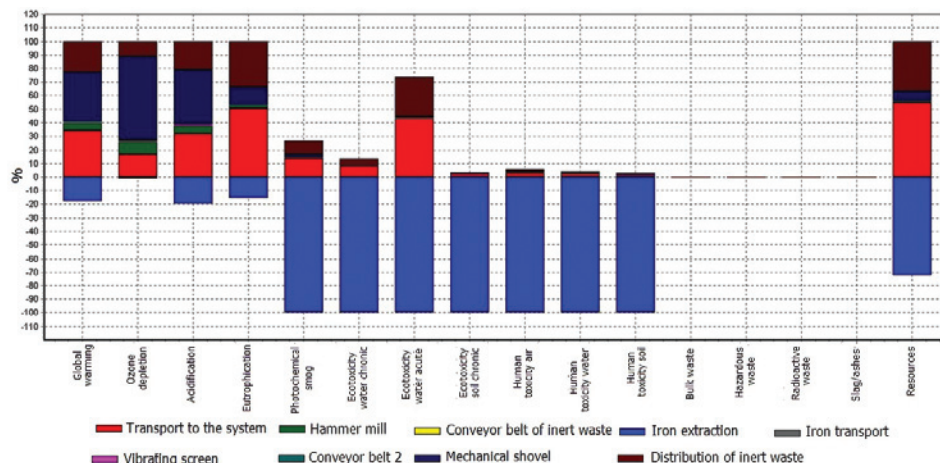

Fig. 15. Characterization of impacts generated in various phases of C&DW recycling/reuse process assessed with the EDIP/UMIP method

gases emitted in the other phases of C&DW recycling are relative small and therefore can be neglected.

3.3.3. Cumulative Energy Demand method

According to this method, an equivalent of 246.41 MJ is necessary to recycle **one tonne** of C&DW. The extraction of iron saves 60.78 MJ equivalents, while the transport to the recycling plant involves a consumption of 0.38 MJ equivalents, so that we have a positive balance of mining. In Fig. 16 the technological phases with higher energy consumption were compared, neglecting phases that consume less (screening and handling through the web site immediately after the screening, which needs 0.67 MJ equivalents each).

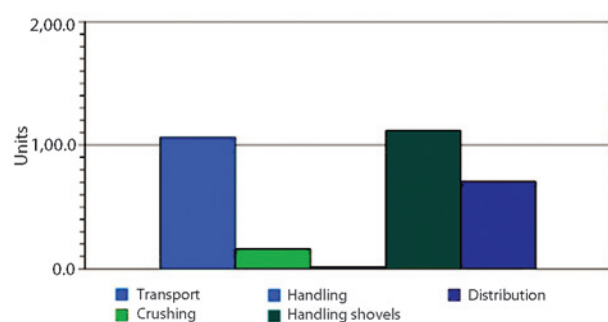

Fig. 16. Energy of individual phases for C&DW recycling/reuse

Handling shovels is the phase with higher energy consumption, followed by transport of waste and the distribution of aggregate. To reduce the environmental impact of C&DW recycling it is necessary to improve or remove the three phases mentioned above.

Conclusions

In this study, we applied LCA to quantify the environmental impacts in C&DW recycling/reuse, specifically in the production of *aggregate* 0/30 mm. A comparison was performed with the environmental performance of natural inert processing, in terms of global impacts addressing the whole process and for each technological phase. Three methods were used for impact quantification of the two scenarios: *Eco-Indicator 99*, *EDIP/UMIP* and *Cumulative Energy Demand*, according to Life Cycle Assessment methodology, supported by SimaPro 7.3.3 software, and based on primary data collected directly from the Italian Emilia Romagna region.

The comparison of the two scenarios – the production of *aggregate* from crushed inert (*scenario 1*) and C&D waste inert (*scenario 2*), with the mentioned methods showed that the recycling process generates a significantly lower environmental impact compared to that resulted from the natural inert processing, as regards

the emission of pollutants, the consequences on human and ecosystems health, the amount of energy consumed. It should be noted that, in the process of recycling, recovery of iron has a positive impact on reducing the consumption of raw materials and energy consumed. Substantial differences appear between the two processes in terms of global warming potential, since the production of 1 tonne of *aggregate* from crushed inert generates 103,000 g of CO₂ equivalent, compared with 15,500 g of CO₂ generated from the recycling of C&DW (almost 7 times lower). A similar argument applies to the acidification and eutrophication, assessed in terms of SO₂ and N₂O₄ emissions.

The technological phase with the higher environmental impact and energy consumption is extraction of minerals, followed by transport and handling.

Apart from the above mentioned aspects, recycling of C&DW has several advantages, including: reducing the exploitation of non-renewable raw materials; reduction in the number and size of the landfill; creation of a material to replace natural raw materials such as gravel and sand, with equivalent performance. However, the selective collection of various components of C&DW should be helpful to ensure the efficiency of the recycling process.

Assessing the costs of recycling technologies, emerging affordability to promote these solutions rather than conventional disposal in landfills, the eco-tax introduced for the disposal of waste has contributed to this condition benefit of recycling.

Considering the mentioned positive effects associated to the C&DW recycling/reuse, from both environmental and economical perspectives, it would be necessary to strengthen the market for recycled aggregates, especially in the perspective of sustainable development in the construction sector.

Acknowledgement

This paper was carried out with the support of: POSDRU CUANTUMDOC “Doctoral Studies for European Performances in Research and Innovation” ID_79407 project funded by the European Social Fund and Romanian Government; PERFORM-ERA “Postdoctoral Performance for Integration in the European Research Area” (ID-57649), financed by the European Social Fund and the Romanian Government. The research was also supported by the grant of the Romanian National Authority for Scientific Research, CNCS – UEFISCDI, project number PN-II-ID-PCE-2011-3-0559, contract 265/2011. Part of the research was supported by the European Union’s Seventh Framework Programme (FP7/2007-2013) under grant agreement n°264115 – *STREAM*.

References

- Agamuthu, P. 2008. Challenges in sustainable management of construction and demolition waste, *Waste Management & Research* 26: 491–492. <http://dx.doi.org/10.1177/0734242X08100096>
- Balázs, S.; Antonini, E.; Tarantinic, M. 2012. *Application of Life Cycle Assessment (LCA) methodology for valorization of building demolition materials and products* [online], [cited 10 September 2012]. Available from Internet: <http://www1.coe.neu.edu/~smgupta/4193-56-SPIE.PDF>
- Bonoli, A.; Garfi, M. 2008. The recycling of construction and demolition waste: the quality standards for the reuse in construction field, in *REWAS 2008, Global Symposium on Recycling, Waste Treatment and Clean Technology proceedings, WARRENDALE PA, TMS*, 1163–1169.
- Bonoli, A.; Fabbri, S.; Goldoni, S. 2006. Demolition techniques and enhancement of waste from C&D, in *Recycling* 115–122 (in Italian).
- Bressi, G. 1999. Recycling technologies of waste from C&D, in *The Recycling in Construction Aggregates*. Palermo, 4 June, 1999 (in Italian).
- Bressi, G.; Puia, P. 2000. Aggregates from recycling: logistics and environmental issues in the economic evaluation of their use, in *Magenta*. Milano, 30 November, 2000 (in Italian).
- Bribián, I. Z.; Capilla, A. V.; Uson, A. A. 2011. Life cycle assessment of building materials: comparative analysis of energy and environmental impacts and evaluation of the eco-efficiency improvement potential, *Building and Environment* 46: 1133–1140. <http://dx.doi.org/10.1016/j.buildenv.2010.12.002>
- Coelho, A.; de Brito, J. 2013. Environmental analysis of a construction and demolition waste recycling plant in Portugal – Part I: energy consumption and CO₂ emissions, *Waste Management* 33(5): 1258–1267. <http://www.dx.doi.org/10.1016/j.wasman.2013.01.025>
- Cochran, K.; Townsend, T.; Reinhart, D.; Heck, H. 2007. Estimation of regional building-related C&D debris generation and composition: case study for Florida, *Waste Management* 27: 921–931.
- Comandaru, I. M.; Barjoveanu, G.; Peiu, N.; Ene, S. A.; Teodosiu, C. 2012. Life cycle assessment of wine: focus on water use impact assessment, *Environmental Engineering and Management Journal* 11: 533–543.
- Coronado, M.; Dosal, E.; Coz, A.; Viguri, J. R.; Andres, A. 2011. Estimation of construction and demolition waste (C&DW) generation and multicriteria analysis of C&DW management alternatives: a case study in Spain, *Waste and Biomass Valorization* 2: 209–225. <http://dx.doi.org/10.1007/s12649-011-9064-8>
- Cupo-Pagano, M.; D'Andrea, A.; Giavarini, C.; Marro, C. 1994. Use of building demolition waste for asphalt mixes: first results, in *Energy, Environment and Technological Innovation – Proceedings of III International Congress*, 5–11 November, 1994, Caracas – Venezuela, 203–208.
- Curan, M. A. 1996. *Environmental Life-Cycle Assessment*. McGraw-Hill Professional Publishing.
- D'Andrea, A. 1999. Aggregates recycling: characteristics, fields use, recycling of inert waste in construction, in *Proceedings of the National Conference*, Palermo, 81–103 (in Italian).
- Dall'Ara, A.; Bonoli, A.; Serranti, S. 2012. An innovative procedure to characterize properties from tailored composts, *Environmental Engineering and Management Journal* 11: 1825–1832.
- Dosal, E.; Coronado, M.; Munoz, I.; Viguri, J. R.; Andres, A. 2012. Application of multi-criteria decision-making tool to locate construction and demolition waste (C&DW) recycling facilities in a northern Spanish region, *Environmental Engineering and Management Journal* 11: 545–556.
- EC Directive. 2008. Directive 2008/98/EC of the European Parliament and of the Council of 19 November 2008 on Waste and Repealing Certain Directives, *Official Journal of the European Union* L 312: 3–30.
- Edge Environment. 2011. *Construction and demolition waste guide – recycling and re-use across the supply chain, Department of Sustainability, Environment, Water, Population and Communities* [online]. Australian Government, Canberra, Australia. Available from Internet: <http://www.environment.gov.au/wastepolicy/publications/pubs/case-studies.pdf>
- EPA, 2002. *Construction and Demolition Waste, Waste Management and Resource Use Opportunities, Queensland*. Environmental Protection Agency, Brisbane, Australia.
- Eurostat. 2013. *Statistics Database 2013, Waste Statistics* [online]. Available from Internet: http://epp.eurostat.ec.europa.eu/portal/page/portal/waste/waste_generation_management/generation/construction
- Fortuna, M. E.; Simion, I. M.; Ghinea, C.; Petraru, M.; Cozma, P.; Apostol, L. C.; Hlihor, R. M.; Fertu, D. T.; Gavrilesco, M. 2012. Analysis and management of specific processes from environmental engineering and protection based on sustainability indicators, *Environmental Engineering and Management Journal* 11: 333–350.
- Gavrilescu, M. 2004. Cleaner production as a tool for sustainable development, *Environmental Engineering and Management Journal* 3: 45–70.
- Georgakellos, D. A. 2011. Determining the level of subsidies for environmental friendly technology vehicles, *Environmental Engineering and Management Journal* 10: 1495–1502.
- Ghinea, C.; Gavrilesco, M. 2010. Decision support models for solid waste management – an overview, *Environmental Engineering and Management Journal* 9: 868–880.
- Ghinea, C.; Petraru, M.; Bressers, H. Th. A.; Gavrilesco, M. 2012. Environmental evaluation of waste management scenarios – significance of the boundaries, *Journal of Environmental Engineering and Landscape Management* 20(1): 76–85. <http://dx.doi.org/10.3846/16486897.2011.644665>
- Goedkoop, M.; Oele, M.; De Schryver, A.; Vieire, M.; Hegger, S. 2010. *SimaPro Database Manual. Methods library*. The Netherlands: PRÉ Consultants.
- Gorgolewski, M.; Straka, V.; Edmonds, J.; Sergio, C. 2006. *Facilitating greater reuse and recycling of structural steel in the construction and demolition process*: Final report. Canadian Institute of Steel Construction, 3–63.
- Ionescu, S.; Deac, V.; Corpodean, C. 2011. Risk of exposure to asbestos in case of the mechanical degradation of some asbocement composites, *Environmental Engineering and Management Journal* 9: 1773–1777.
- Iosip, A.; Hortal, M.; Dobón, A.; Bobu, E. 2010. Comparative environmental impact assessment of corrugated board production, *Environmental Engineering and Management Journal* 9: 1281–1287.
- ISO 14040: 2006a. *Environmental management – Life cycle assessment – Principles and framework*. European Standard

- EN ISO 14040. The International Organization for Standardization, Geneva, Switzerland.
- ISO 14044: 2006b. *Environmental management – Life cycle assessment – Requirements and Guidelines*. European Standard EN ISO 14040. The International Organization for Standardization, Geneva, Switzerland.
- Kazemi, S.; Peiu, N.; Macoveanu, M. 2012. Waste management: A Life Cycle perspective, *Environmental Engineering and Management Journal* 11: 1639–1648.
- Khasreen, M.; Banfill, P.; Menzies, G. 2009. Life-cycle assessment and the environmental impact of buildings: a review, *Sustainability* 1: 674–701. <http://dx.doi.org/10.3390/su1030674>
- Koroneos, C.; Dompros, A. 2007. Environmental assessment of brick production in Greece, *Building and Environment* 42: 2114–2123. <http://dx.doi.org/10.1016/j.buildenv.2006.03.006>
- Kourmpanis, B.; Papadopoulos, A.; Moustakas, K.; Stylianou, M.; Haralambous, K. J.; Loizidou, M. 2008. Preliminary study for the management of construction and demolition waste, *Waste Management & Research* 26: 267–275. <http://dx.doi.org/10.1177/0734242X07083344>
- Mymrin, V.; Correa, S. M. 2007. New construction material from concrete production and demolition wastes and lime production waste, *Construction and Building Materials* 21: 578–582. <http://dx.doi.org/10.1016/j.conbuildmat.2005.09.007>
- Petraru, M.; Gavrilescu, M. 2010. Pollution prevention: a key to economic and environmental sustainability, *Environmental Engineering and Management Journal* 9: 597–614.
- Pittalis, C. 2009. *Inert waste from C & D: technologie recycling and applicazionie of LCA methodology for the production of stabilized inert 0/30 mm*: PhD Thesis. Coordinator Bonoli, A. Faculty of Ingineery, Alma Mater Studiorum Universita di Bologna.
- Poon, C. S. 2007. Management of construction and demolition waste, *Waste Management* 27: 159–160. <http://dx.doi.org/10.1016/j.wasman.2007.08.013>
- Powell, J. C.; Craighill, A. L.; Parfitt, J. P.; Turner, R. K. 1996. A lifecycle assessment and economic valuation of recycling, *Journal of Environmental Planning and Management* 39: 97–112. <http://dx.doi.org/10.1080/09640569612697>
- Rigamonti, L.; Grosso, M.; Giugliano, M. 2009. Life cycle assessment for optimizing the level of separated collection in integrated MSW management system, *Waste Management* 29: 934–944.
- del Rio Merino, M.; Izquierdo Gracia, P.; Salto Weis Azevedo, I. 2010. Sustainable construction: construction and demolition waste reconsidered, *Waste Management and Research* 28: 118–129. <http://dx.doi.org/10.1177/0734242X09103841>
- Robu, B. M.; Caliman, F. A.; Betianu, C.; Gavrilescu, M. 2007. Methods and procedures for environmental risk assessment, *Environmental Engineering and Management Journal* 6: 573–592.
- SARMa, 2011. *Life Cycle Assessment (LCA) guidelines to be used in the SARMa project. Definition of a common methodology to boost use of LCA tools in sustainable production and recycling of aggregates*. 15 February, 2011. 60 p.
- Schiopu, A.-M.; Gavrilescu, M. 2010. Municipal solid waste landfilling and treatment of resulting liquid effluents, *Environmental Engineering and Management Journal* 9: 993–1019.
- Schiopu, A. M.; Piuleac, G. C.; Cojocaru, C.; Apostol, I.; Mama-liga, I.; Gavrilescu, M. 2012. Reducing environmental risk of landfills: leachate treatment by reverse osmosis, *Environmental Engineering and Management Journal* 11: 2319–2331.
- Simion, I. M.; Fortuna, M. E.; Gavrilescu, M. 2012. *Use of sustainable indicators in solid waste management – a review*, Bulletin of the Polytechnic Institute of Iasi, Tome LVIII (LXII), Fasc. 1, 57–71.
- Simion, I. M.; Ghinea, C.; Maxineasa, S. G.; Taranu, N.; Bonoli, A.; Gavrilescu, M. 2013. Ecological footprint applied in the assessment of construction and demolition waste integrated management, *Environmental Engineering and Management Journal* 12: 779–788.
- Solis-Guzmán, J.; Marrero, M.; Montes-Delgado, M. V.; Ramirez-de-Arellano, A. 2009. A Spanish model for quantification and management of construction waste, *Waste Management* 29: 2542–2548.
- Taboada-González, P.; Aguilar-Virgen, Q.; Ojeda-Benítez, S.; Armijo, C. 2012. Waste characterization and waste management perception in rural communities in Mexico: a case study, *Environmental Engineering and Management Journal* 11: 1751–1759.
- Taranu, N.; Oprisan, G.; Entuc, I.; Budescu, M.; Munteanu, V.; Taranu, G. 2012. Composite and hybrid solutions for sustainable development in civil engineering, *Environmental Engineering and Management Journal* 11: 783–793.
- Vasquez, E. 2013. Overview regarding construction and demolition waste in several countries, in Vasquez, E. (Ed.). *Progress of Recycling in the Built Environment: Rilem State-of-the-Art Reports* 8: 37–174. London: Springer.
- Vlase, R.; Iftimi, V.; Gavrilescu, D. 2012. Sustainable use of recovered paper – Romanian paper industry, *Environmental Engineering and Management Journal* 11: 2077–2082.
- Wiesmeth, H.; Hackl, D. 2011. How to successfully implement extended producer responsibility: considerations from an economic point of view, *Waste Management and Research* 29: 891–901. <http://dx.doi.org/10.1177/0734242X11413333>
- Yeheyis, M.; Hewage, K.; Shahria Alam, M.; Eskicioglu, C.; Sadiq, R. 2012. An overview of construction and demolition waste management in Canada: a lifecycle analysis approach to sustainability, *Clean Technical Environmental Policy* 15(1): 81–91. <http://dx.doi.org/10.1007/s10098-012-0481-6>

Isabela Maria SIMION. PhD student since October 2010 and from 2011 assistant researcher in a IDEI Project, at Faculty of Chemical Engineering and Environmental Protection, “Gheorghe Asachi” Technical University of Iasi. Holds a Master’s degree in Environmental Engineering and Management (2010) and a Bachelor’s degree in Environmental Engineering (2009), both from “Gheorghe Asachi” Technical University of Iasi. Her research focuses on solid waste management, life cycle assessment, sustainable development, sustainable indicators, ecological footprint.

Maria Emilian FORTUNA. PhD, Researcher at Institute of Macromolecular Chemistry “Petru Poni” Iasi. PhD degree (Department of natural and synthetic polymers – 2008), Master’s degree in Environmental Engineering and Management (2004) at “Gheorghe Asachi” Technical University of Iasi and a Bachelor’s degree Chemical Engineering (2003) at “Al. I. Cuza” University of Iasi. Her research focuses on impact of paper recycling, electrochemical methods for industrial water treatment, sustainable development, ecological footprint.

Alessandra BONOLI. Associate Professor at the Department of Civil Engineering, Chemistry, Environmental and Materials, Alma Mater Studiorum University of Bologna, Italy. Teaching and research interests: mineral processing, solid materials and waste recycling, water supply, water resource sustainable utilization, waste water treatment and recycling, environmental management and sustainability, life cycle assessment, appropriate environmental technologies for developing countries.

Maria GAVRILESCU. Professor at the Department of Environmental Engineering and Management of the “Gheorghe Asachi” Technical University of Iasi, Romania, where she teaches courses in Chemical and Biological Process Engineering, Process Synthesis and Analysis, Integrated Pollution Prevention and Control, Sustainable Industrial Production and Environmental Risk Assessment and Management. She has published numerous books and articles in the fields of chemical and environmental engineering, pharmaceutical and environmental biotechnology, pollution prevention and cleaner production, risk assessment and management, which include over 400 titles.